

***Luxor 16 Tablet/
Chromebook Open
Charging Cart - LOTM16***

Spec Sheet



Provided by

MyBinding.com

When Image Matters.

Call Us at 1-800-944-4573

LOTM16

16 Unit Open Tablet/Chromebook Charging Cart

Product Specifications

Item Number	LOTM16
Material	Steel
Color Finish	Gray & White
Capacity	16 Chromebooks or tablets
Cart Dimensions	27" W x 14.75" D x 30" H
Weight	37 lbs.
Shelf Quantity	1
Divider Make	Plastic (High Impact Polystyrene)
Divider Distance	1.35" W with 1.25" space between dividers
Divider Slot Dimensions	1.35" W x 8" D x 10.43" H
Electrical Tray Dimensions:	Bottom of Tray: 6.8" D x 24.4" W Top of Tray (opening): 6.1" D x 24.4" W Height of Tray: 3.25" H
Cord Length	10'
Cable Management	Two cord clips per divider
Casters (4)	1.6" casters; two with locking brakes
Weight Capacity	75 lbs.
Power	16-outlet horizontal power strip; UL and cUL Listed
Voltage	120V/15A
Ship Method	Ground
Shipping Carton Dims	1 carton; 33" W x 18" D x 5.25" H
Shipping Weight	41 lbs.
Assembly Required	Yes

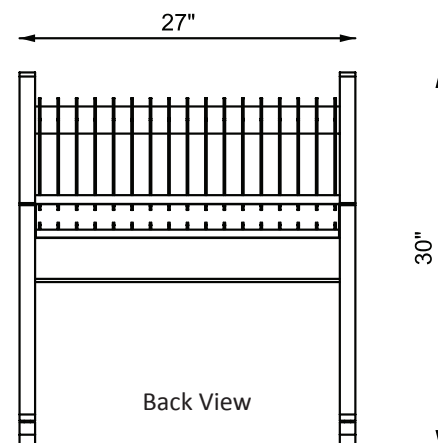
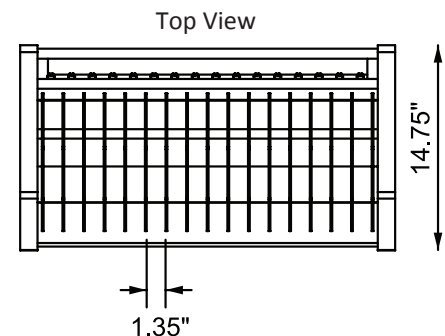
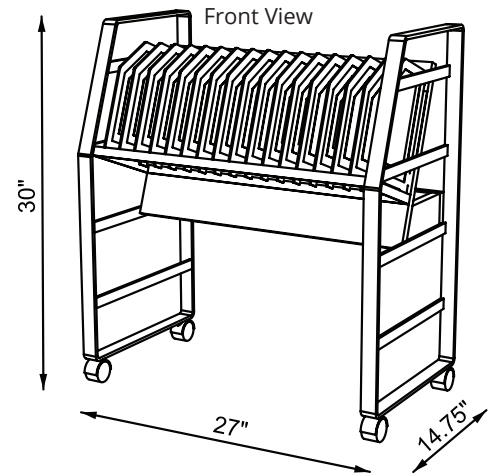

LUXOR

INNOVATIVE WORKSPACE PRODUCT SOLUTIONS



9620 NE Tanasbourne, Dr. Suite 250, Hillsboro, OR 97124

sales@mybinding.com

1-800-944-4573