

# ***Tamerica TPI-4900E 19.29" Programmable Paper Stack Cutter***

Instruction Manual



*Provided by*

**MyBinding.com**  
*When Image Matters.*

Call Us at 1-800-944-4573

# TPI-4806

Programmable Paper Cutter with LCD Display



## USER MANUAL

## Contents

Safety Precautions .....	3
Cabinet Assembly .....	4
Operating buttons / functions .....	5-6
Machine Operation .....	7-11
Convert from Inches to Millimeters / Millimeters to Inches .....	7
Programming in Manual Mode .....	8
Programming in Multi Mode .....	8
Programming in Index Mode .....	9
Cutting your documents in Manual Mode .....	10
Cutting your documents in Automatic and Divide Mode .....	11
Erasing Stored Data .....	11
Schematics.....	12
Parts Manual .....	13-14
Troubleshooting .....	15
Warranty and Return Policy.....	16-17
Machine Specifications and Features .....	18

## IMPORTANT Safety Precautions

It will be beneficial to first get yourself acquainted with the features of your TPI4806 before attempting to use. Keep in mind all operational instructions, tips, and safety reminders every time you use your TPI4806 to best achieve desirable results.

This paper cutter is designed to only cut paper, books, or soft leatherette covers only. Never use the machine to cut any form of metal or other hard objects which may damage the machine.



Children should never be allowed to operate the machine.



Make sure to keep your hands away from the blade at all times & handle the blade with care when replacing and use the supplied blade holder.



Do not use the machine to cut hard materials which may cause injury when it splinters & bits are discharged due to the pressure. This may also damage the blade and the motor.



Make sure the power cord is properly grounded to a dedicated outlet. It is important that a steady flow of current is supplied to the machine for efficiency & the use of a surge protector is highly recommended.



The machine weights approximately 350 lbs. Make sure it is positioned on a clean, dry, flat and stable surface.



Use the emergency stop button to abruptly stop the machine. Turn the knob clockwise to release it and press the RESET button to continue machine operation.

## Cabinet Assembly

Assemble the cabinet stand following the illustration below ensuring all connections are tight and secure. Position the machine on top of the cabinet after assembly.

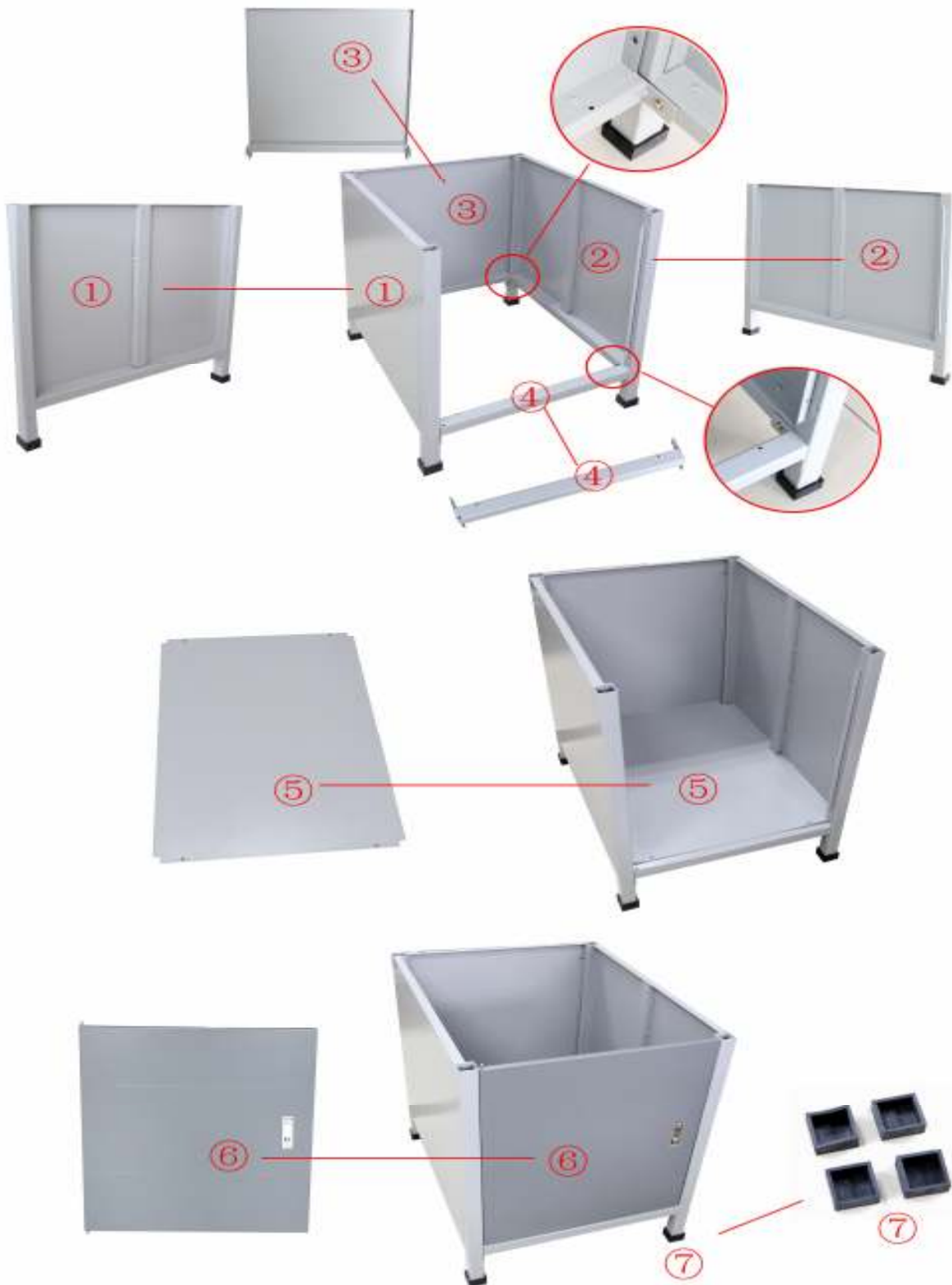

# Operating Buttons and Functions

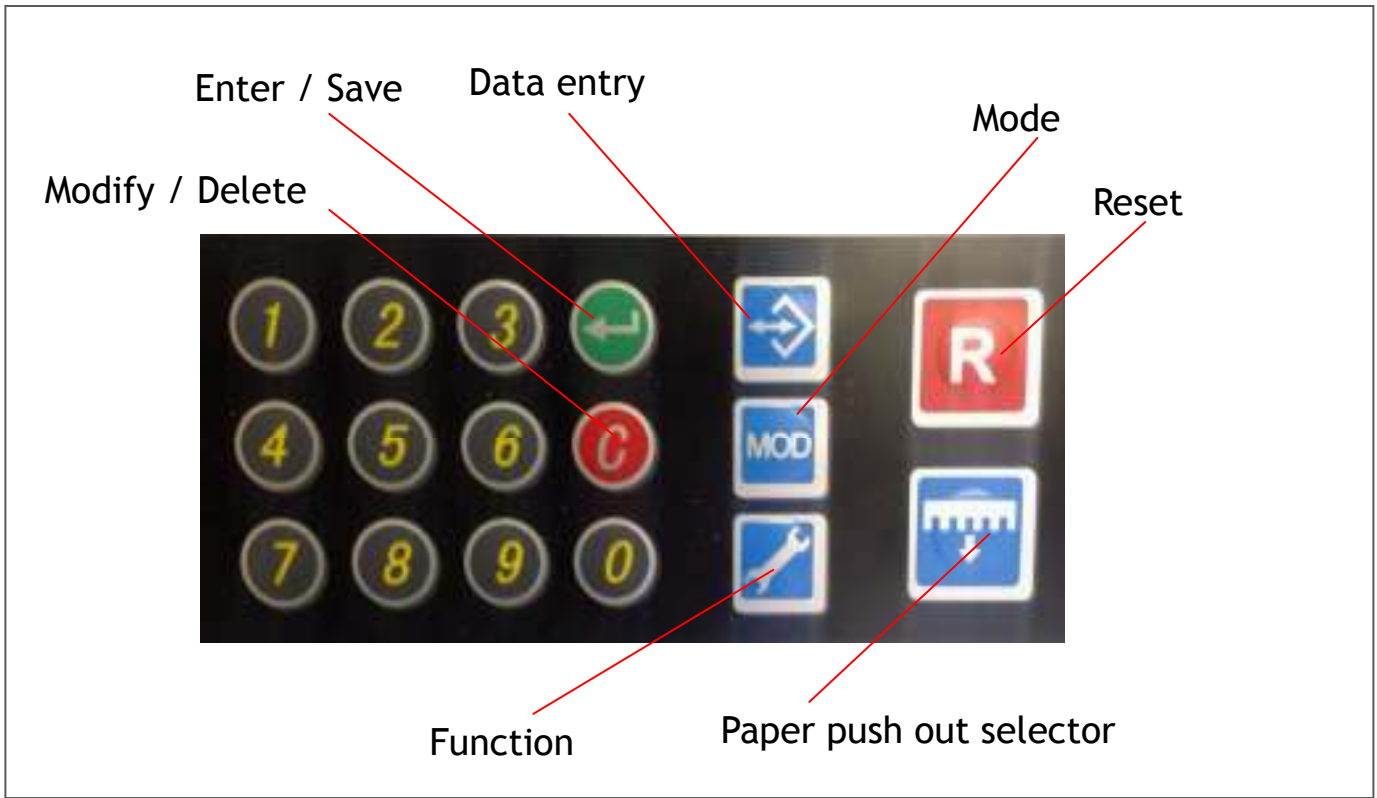

Cut



Clamp



Forward / backward select



+



Press simultaneously to adjust clamp pressure from 1 to 8.



+



Press simultaneously to toggle from manual to automatic paper push out.



+



Press simultaneously to engage the clamp.



Press & hold simultaneously to engage the clamp and operate the blade.



Data entry for automatic and multi mode. (please see pp. 8-9)



Toggle from **Manual Mode** (single cut), **Multi Mode** (100 programmable memory settings with up to 20 cut sizes per setting), and **Index Mode** (100 programmable memory settings with up to 3 cut sizes per setting.)



Manual mode



Multi Mode (M 00 on upper right)



Index Mode (S 00 on upper right)

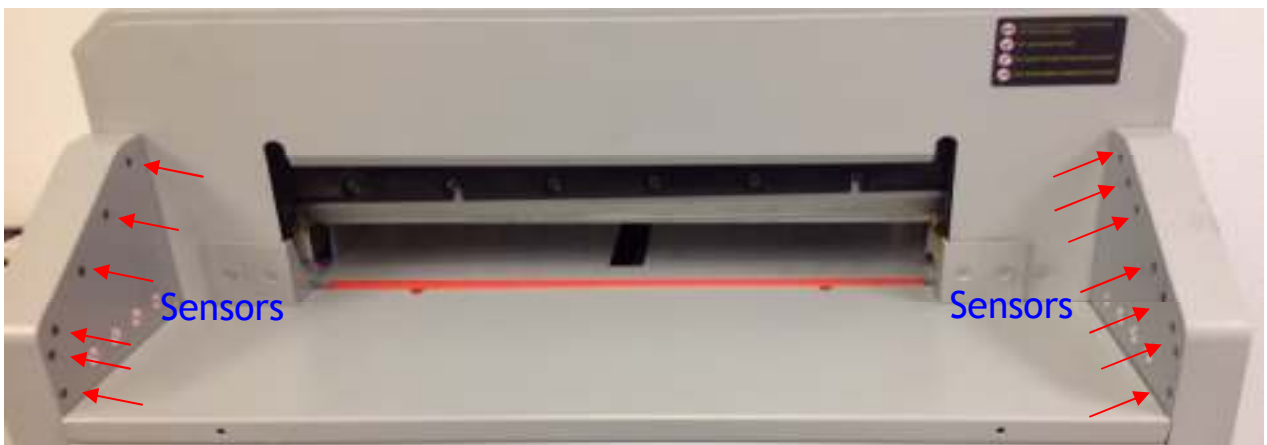

Protective Sensors help keep the user safe from accidents by preventing the machine from operating in the event any of these are blocked.

## Machine Operation



1. Attach the supplied power cord to the back of the machine and plug the other end into a power outlet.



2. Make sure the emergency knob is in the “ON” position. (Move the knob according to the direction of the arrows.)



3. Flip the main toggle switch upwards to the “ON” position.

## Convert from Inches to Millimeters

1. Enter “10.00” on the keypad and press the Enter/Save key.
2. After the back gauge has adjusted to the entered size, press the function key until beeping sound stops then simultaneously press the number “2”



Machine will adjust to 10.00.



Press the Function Key for 2 seconds to highlight the area beside “FUN” (do not release).

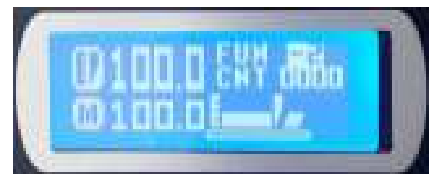

With the Function Key still pressed, simultaneously press “2” on the keypad. The machine will now be set to millimeters.

## Convert from Millimeters to Inches

1. Enter “200.8” on the keypad and press the Enter/Save key.
2. After the back gauge has adjusted to the entered size, press the Function Key until beeping sound stops then simultaneously press the number “2”





Machine will adjust to 200.8.

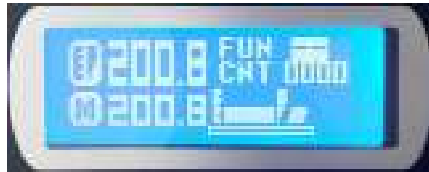

Press the Function Key for 2 seconds to highlight the area beside "FUN" (do not release).



With the Function Key still pressed, simultaneously press "2" on the keypad. The machine will now be set to centimeters.

## Programming in Manual mode

1. Press the Mode Key to go to the desired menu (see p. 6). Enter the desired size and press Enter. In this example, we entered the size 8.50":



2. Press Enter again to the back gauge to adjust to 8.50" then press and hold the 2 cut buttons to cut (see p. 10)

## Programming in Multi-Mode

1. Press the Mode Key to go to the desired menu as described on p. 6 then press the Data Entry key to highlight the area beside "M". Enter the desired number (00-99) then press the Enter Key to save the entry. In this example, we entered the number 1.

*\*You program up to 100 memory settings (M 00-99)*

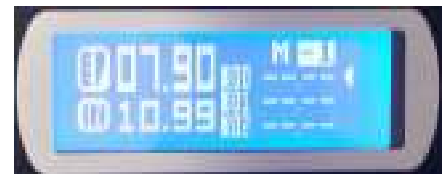

2. Press the CLEAR key for 1-2 secs. to highlight the entry you want to save a cut size on, (E00-E20, 20 entries total), input the number, then press Enter. This will automatically move the cursor to the next entry #. Input the second number then press Enter and repeat the process until you have entered all your cut sizes. After the last entry, press the Enter Key this time for about 2 seconds to save all entries. The cursor will move to the first saved size.

In this example, we entered 8.00” on the 1st entry, 6.50” for the second, and 4.50” for the third. Remember to press the Enter Key for 2 secs. to save all entries and then press it again for the back gauge to adjust to the first size.



Highlight the entry # by pressing the Clear Key for 1-2 secs.



Enter the sizes and press the Enter Key for 2 secs. to save all entries)



The cursor will move back to the first size after all entries have been saved. (Back gauge has not adjusted yet.)

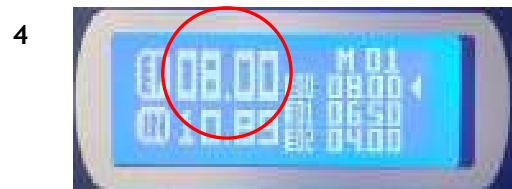

Press Enter again for the back gauge to adjust to the first saved size (8.00”).

With the back gauge at 8.00”, pressing the 2 cut buttons simultaneously (p. 11) will make the first cut at 8.00”, pressing them again will cut at 6.50”, then 4.00”, all the way to the last size saved.

## Programming in Index Mode

1. Press the Mode Key to go to the desired menu (see p. 6) then press the Data Entry Key to highlight the area beside “S”. Enter the desired number (\*0-99) then press the Enter Key to save the entry. In this example, we entered the number 11.

*\*The machine can save up to 100 memory settings, (S 00-99).*

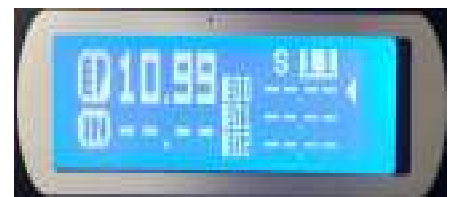

2. Press the CLEAR key for 1-2 secs. to highlight the entry # you want to save a cut size on (E00-E02, 3 entries total), input the number, then press Enter. This will automatically move the cursor to the next entry #. Input the second number then press Enter and repeat the process until you have entered all your cut sizes. After your last entry, press the Enter Key for about 2 seconds to save all entries into the memory bank.

In this example, we entered 10.00” on the first entry and 2.00” for the second. Remember to press the Enter Key for 2 secs. to save all entries and then press it again for the back gauge to adjust to the first size.



Highlight the entry # by pressing the Clear Key for 1-2 secs.



Enter the sizes and press the Enter Key for 2 secs. to save all entries)



The cursor will move back to the first size after all entries have been saved. (Back gauge has not adjusted yet.)



Press Enter again for the back gauge to adjust to the first saved size (10.00”).

With the back gauge at 10.00”, pressing the 2 cut buttons simultaneously will cut the document at 10” followed by 2” cuts for each corresponding cut thereafter.

## Cutting your documents in Manual Mode

After entering the desired cut size, simultaneously press the 2 Cut buttons to cut.

You may program the machine to push your document out after each cut by simultaneously pressing the paper push out and paper clamp buttons.



Manual paper push.



Automatic paper push.

## Cutting your documents in Multi and Index Mode

1. After the back gauge has adjusted to the first saved cut size, press the 2 Cut buttons simultaneously.
2. You may release the 2 buttons as soon as the blade touches the cutting stick.
3. Press the 2 Cut buttons again for the next cut after the machine's back gauge has adjusted to the next saved cut size. Repeat above steps until the last cut.
4. Press the Paper Push button after the last cut.



Simultaneously press the 2 Cut buttons to cut the document.



Press the Paper Push Out button after the last cut to move the document out of the cutting throat.

## Erasing saved data

1. Go to the desired memory setting.
2. Press the Clear button for 2-3 seconds to highlight the entry you want erased.
3. Press Clear again to erase it then press the down arrow key to go to the next entry (it will be highlighted automatically.)
4. Press Enter for 2-3 seconds after all entries have been erased to permanently delete previously saved data.



Highlight the entry you want erased by pressing the clear button for 2-3 secs.



Press clear again to erase the data all at once.



Press the down arrow key to go to the next entry.



Press the Enter Key for 2-3 seconds to permanently delete all entries. The cursor will move back to the first entry.

# Schematics (AC MOTOR)

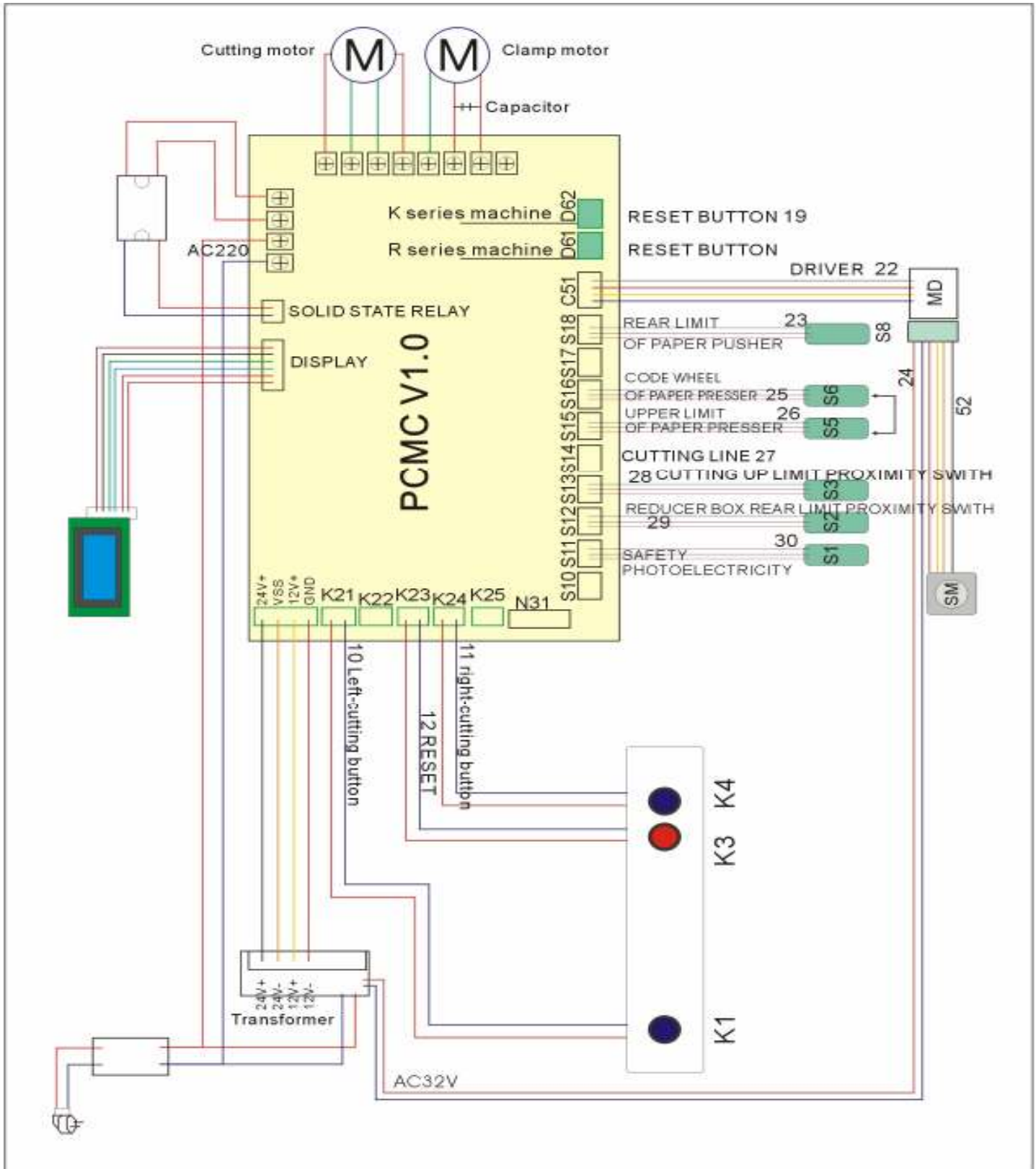

Note: The circuits for the model TPI4806 need a main line 25 and line 26 for the switch (see diagram).

# Parts Manual

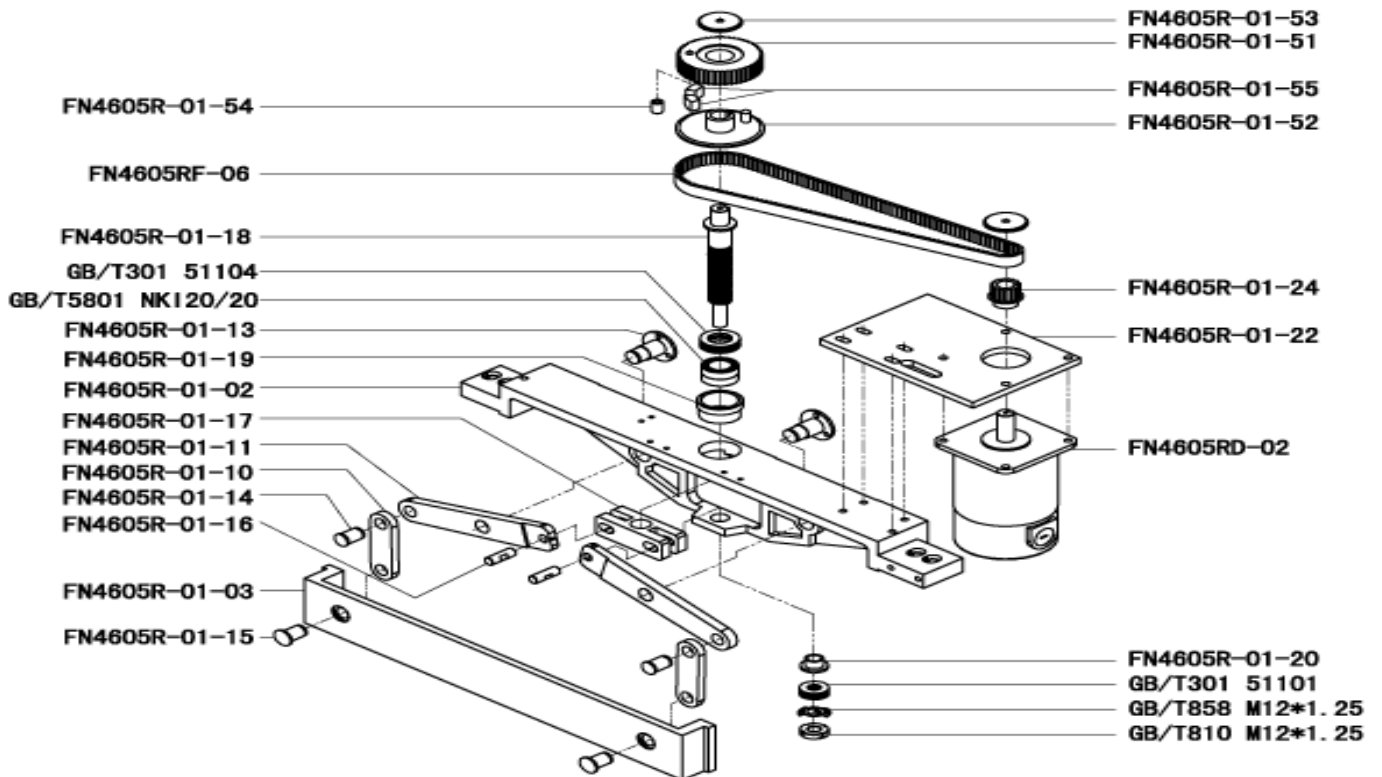
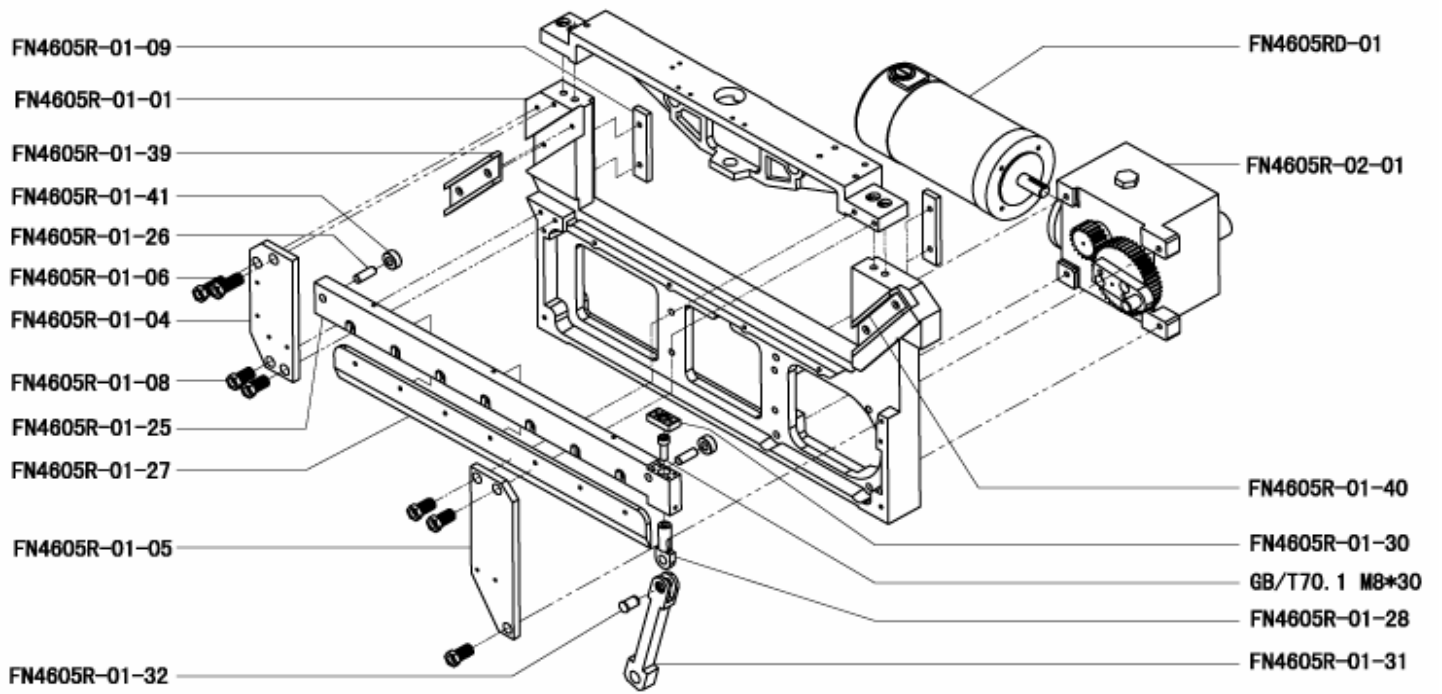

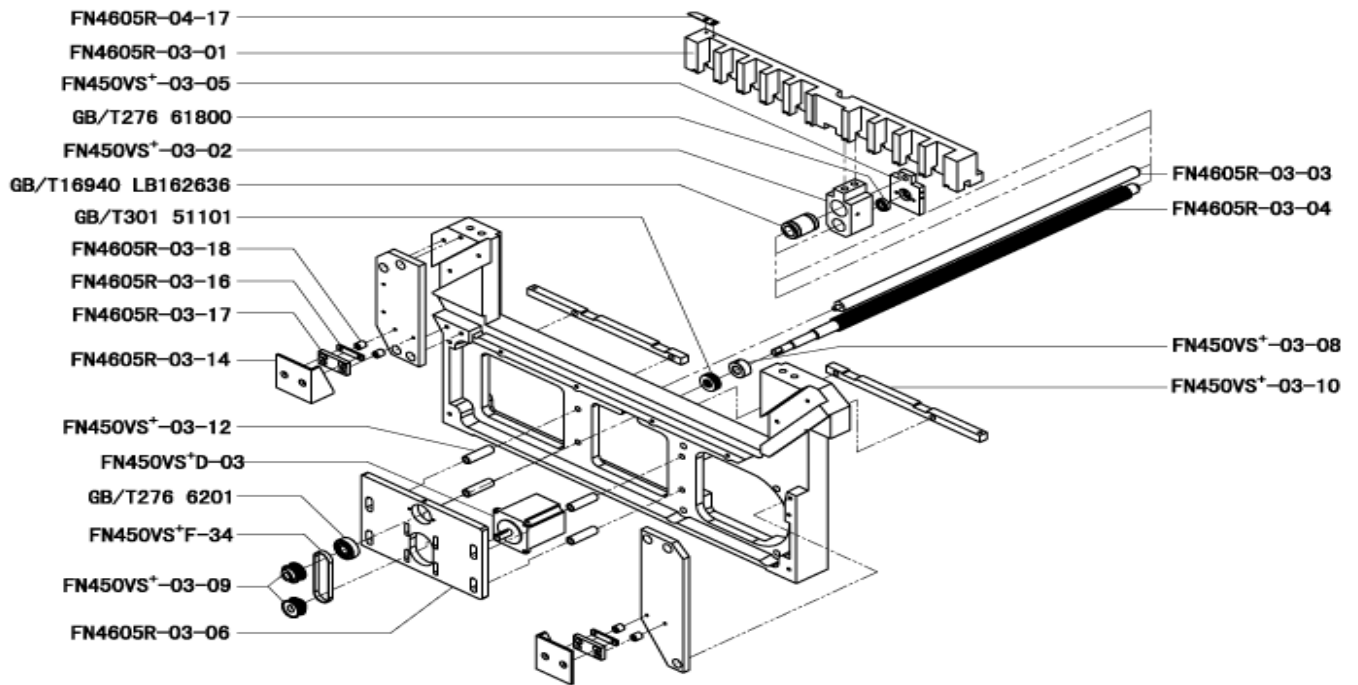

Mod. FN4605R 4/4

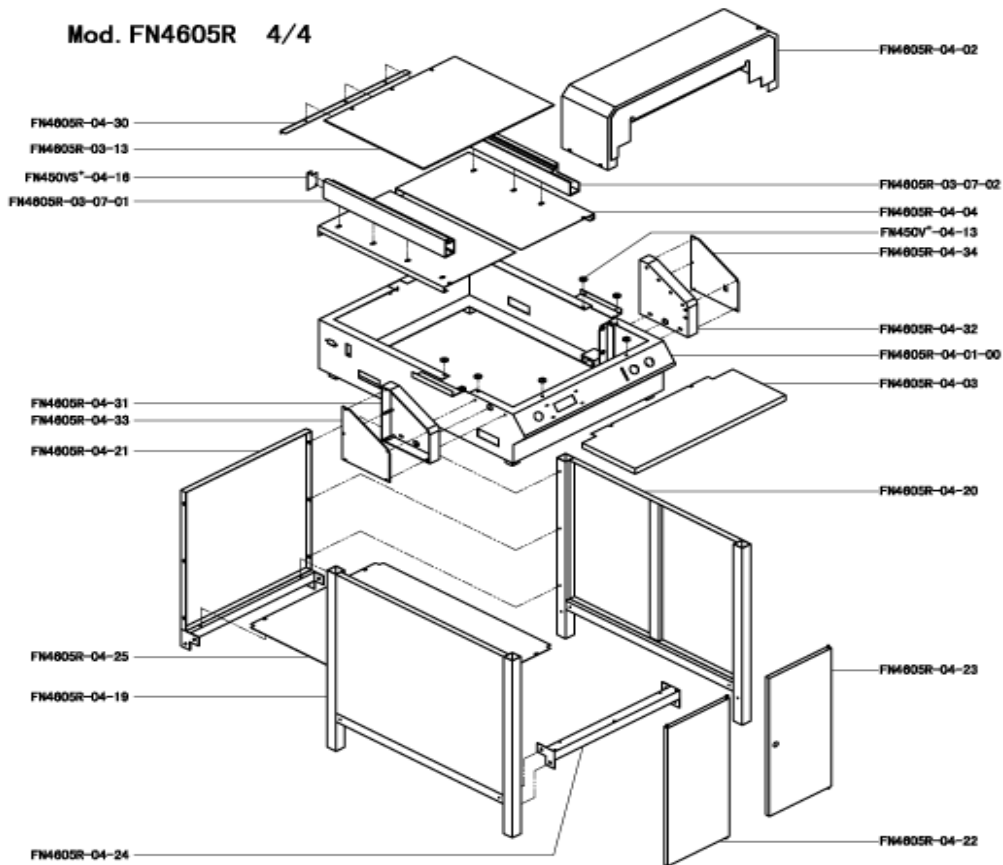

## Troubleshooting

Uneven / inaccurate cut on cut media.	Adjust ruler and check if paper pusher board is aligned (squared).
Blade will not completely retract or will not stop cutting no matter which buttons are pressed.	<ol style="list-style-type: none"> <li>1. Check the sensor which may have be misaligned or damaged.</li> <li>2. Check the main board.</li> </ol>
LCD screen malfunction even if Reset Key is pressed.	Check internal connections to see if any of the connectors have gotten loose.
Paper push out mechanism will not move.	<ol style="list-style-type: none"> <li>1. Check motor.</li> <li>2. Check for any signs of damage on the main circuit board.</li> </ol>
Alarm / error code E-1 – key/button function is invalid and cutting operation stops	<ol style="list-style-type: none"> <li>1. Check the flash.</li> <li>2. Check control panel.</li> </ol>
Alarm / error code E-2 – machine cuts but the blade will not retract properly.	<ol style="list-style-type: none"> <li>1. Check the blade’s limit sensor.</li> <li>2. Check the main board.</li> </ol>
Alarm / error code E-4 – press shelf return is abnormal.	<ol style="list-style-type: none"> <li>1. Check limit sensor on the press shelf.</li> <li>2. Check the main board.</li> </ol>
Alarm / error code E-5 – pressing is not normal.	<ol style="list-style-type: none"> <li>1. Check pressing motor code wheel sensor.</li> <li>2. Check the main board.</li> </ol>
Alarm / error code E-6 – machine cuts but the paper push out mechanism will not adjust.	<ol style="list-style-type: none"> <li>1. Check the pressing motor backward calibration sensor.</li> <li>2. Check the main board.</li> </ol>



## Warranty Information



This machine is guaranteed against defects in materials and workmanship for a period of one (1) year from the date of original purchase from an authorized distributor of TAMERICA PRODUCTS, INC. Customers are to report to the authorized distributor they purchased the machine from any perceived or experienced issue about the machine within 10 days of said purchase to avail of free pickup and redelivery from TAMERICA'S Service Center.

After the first 10 days, customers would either receive service instructions and parts via mail free of charge for the duration of the warranty, or be responsible for shipping the machine to the dealer or to the TAMERICA Service Center through the life of the machine.

Note that when returning the machine for warranty claims, the machine should be returned in its complete original packaging to avoid incidental or consequential damages that may void the claim. A copy of the invoice or other proof of purchase also needs to be sent with the machine.

Upon evaluation of the machine and the determination of the actual defect, the machine will be restored to its working condition by the Service Center and shipped back to the customer free of charge.

If a customer changes their mind and want to return the machine for a refund, they must do so within the 10-day grace period. However, a 20% restocking fee will be charged plus they will have to cover freight cost to send the machine back which may include other expenses incurred to restore the machine to brand-new, resalable condition.

**This warranty covers all defects incurred in the normal use of the equipment, except in the following cases:**

1. Loss or damage to the equipment due to improper operation, abuse, mishandling or failure to follow the operating instructions.
2. Removal or alteration of the serial number.
3. The machine being serviced or modified by anyone other than a certified technician authorized by TAMERICA

This warranty expresses the entire obligation of TAMERICA PRODUCTS, INC. Unless prohibited by law, neither this warranty nor any other warranty expressed or implied, including implied warranties of merchantability, shall extend upon this warranty period. No responsibility is assured for incidental or consequential damages.

## General Return Policy

1. All claims must be made within 10 business days after receipt of merchandise. This statement is printed on all or invoices.
2. Our products are warranted to be within manufacturer's specifications, but no warranty of fitness for purpose is expressed. This statement is printed on all our picking sheets.
3. Merchandise may not be returned without our approval and an RA number.
4. A 20% restocking fee is charged on returns. Exceptions of less than 20% restocking fee may be charged when authorized by management.
5. Merchandise shipped from our warehouse is always in good condition and in general, our term of sale is FOB origin. If the entire shipment was damaged by a freight carrier while in transit, customer should refuse delivery. If only a portion of the shipment was damaged, details of the damage must be clearly indicated on the delivery receipt. Otherwise, claims will not be accepted.
6. The exception for item #5 above is "concealed damage" where it is physically impossible to note the damage at the time of delivery. In this case, the customer must in good faith, immediately inform us or the authorized dealer they purchased the machine from, about the damage/s. However, consistent with #3 above, all claims must still be made within 10 business days after receipt.
7. Return freight must be paid by the customer. Exceptions are as follows:
  - We shipped the wrong merchandise
  - The machine is determined to be under warranty but should be returned within 10 days upon receipt of machine.

## Customer's Responsibilities:

1. The merchandise must be in good, resalable condition.
2. While the machine is still under its warranty period, the original packaging must be kept. If the merchandise is not in its original packaging, cost to repair damages while in transit must be paid by the customer. Please note clear instructions stamped on the box of each machine.
3. The RA number must be indicated on the carton. Otherwise, returns will be refused. Exception: When a call tag is issued by us or the dealer for the return of the merchandise.

## Features

- Automatic clamping with separate motor.
- Fully programmable paper push system.
- Laser cutting line.
- Automatic retractable blade.
- Adjustable blade depth.
- Protective acrylic back cover.
- Emergency stop button.

## Technical Details

Model	: TPI4806
Max. Cutting Length	: 480mm (18.9")
Max. Cutting Thickness	: 60mm (2.36")
Table Depth	: 480mm(18.9")
Minimum Cutting Size	: 40mm (1.57")
Clamping System	: Automatic
Paper Pushing System	: Programmable pusher
Power	: AC110 / 60Hz / 1300W
Dimensions	: 935(36.81") x 740(29") x 1235mm(48.62")
Weight	: 150kgs (330lbs)