

Morgana DigiCreaser 33 ***Automatic Creasing*** ***Machine***

Instruction Manual



Provided by

MyBinding.com

When Image Matters.

Call Us at 1-800-944-4573

Morgana DigiCreaser

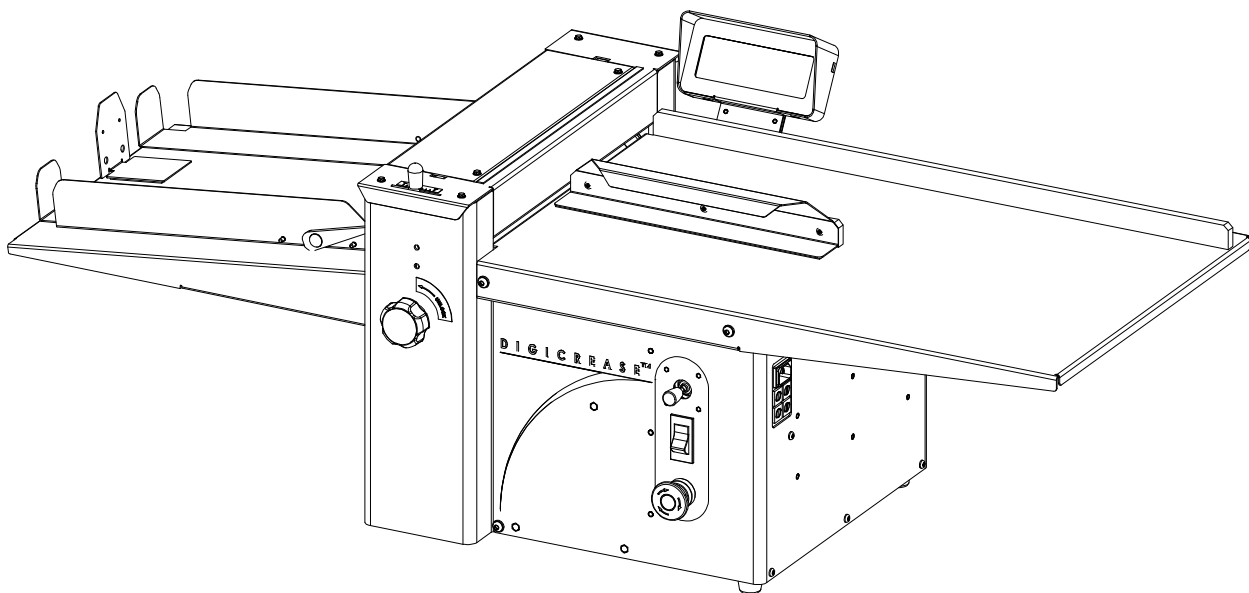

HAND FED DOCUMENT CREASING MACHINE OPERATORS MANUAL

MyBinding.com
5500 NE Moore Court
Hillsboro, OR 97124
Toll Free: 1-800-944-4573
Local: 503-640-5920

ISSUE 5 SEPTEMBER 2007

SERIAL No. 770264KFAD ONWARDS

70-087

INTRODUCTION	
The Morgana Digicreaser	PAGE 3
SAFETY Do's & Don'ts	4
THE DIGICREASER	
Labelled Photograph	6
THE CONTROLS	
The control panel	7
Features on the control panel	7
QUICK START GUIDE	8
OPERATING THE DIGICREASER	
Setting the machine	10
Programming the machine	11
Reading stored programmes	12
Paper jamming	12
THE STACKER ASSEMBLY	
Setting the Stacker unit	13
PERFORATING	
Equipment, spares	15
Setting the machine	16
THE BLADE ASSEMBLY	
Setting the blade pressure	18
Setting the blade alignment	19
REPLACING CREASING BLADE SETS	
Installing new blade sets	20
Spares	21
TROUBLE SHOOTING	22
DISPATCH KIT	24
ACCESSORIES & OPTIONS	25
RECOMMENDED SPARES	26

Morgana DigiCreaser

The Morgana DigiCreaser is a fully automatic, after feeding, creasing system designed for use with both conventional litho and digital printers.

The DigiCreaser is capable of creasing sheet sizes to a maximum of 630mm x 330mm (24.8" x 13") and weights up to 400gsm.

Up to nine creases can be programmed to a single sheet.

The crease is programmed from the leading edge of the sheet using the controls on the front panel.

A minimum distance between creases is 0.1mm.

The DigiCreaser has up to nine available memory addresses for programmed creasing operations.

The blade and anvil are mechanically controlled over their entire length and can be adjusted to accommodate various weights of media.

Safety Do's & Don'ts

Do - read this operator manual fully before operating the machine.

Do - operate with the designated AC current only. Use an exclusive outlet, as overloading may cause fire or an electric shock.

Do - install the power cord out of the way to avoid a tripping hazard.

Do - beware of finger traps when replacing roller cassette and fold plates.

Do not - install the machine in an unstable place such that it tilts or shakes.

Do not - unplug the plug or unplug the power cord from the outlet with a wet hand, this can cause an electric shock.

Do not - unscrew and remove any covers from the machine, as it can cause an electric shock or injury.

Do not - place receptacles containing liquids on any surface.

Do not - adjust any part of the machine whilst rollers are running

Do not - operate the machine with loose or trailing clothing or loose hair.

BLANK
PAGE

*Morgana***Digicreaser****HAND FED DOCUMENT CREASING MACHINE****Key to photograph below**

- | | | | | | |
|---|---------------------|---|------------------|----|------------------|
| 1 | Roller tilt handle | 5 | Back stop | 9 | Control Panel |
| 2 | Stacker assembly | 6 | Fixed side lay | 10 | Fuses |
| 3 | The display unit | 7 | Roller tilt knob | 11 | Stacker Guide LH |
| 4 | Adjustable side lay | 8 | Exit Guard | 12 | Stacker Guide RH |

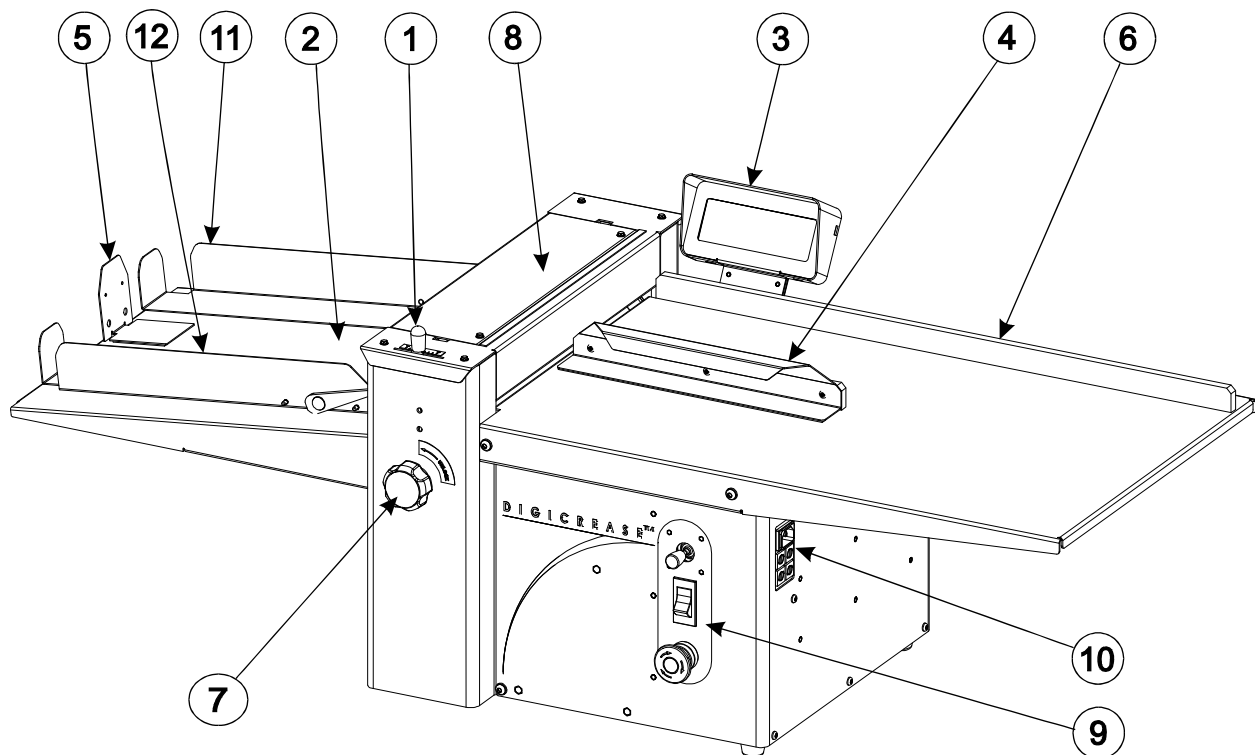

The Display Unit and the Switches on the Control Panel allow the operator to read, edit, create and initiate numerous creasing programs within the memory.

The Control Panel houses the Selection Switch, System Switch, and an industry standard Emergency Stop switch which will stop all power going to the machine when activated.

THE CONTROL PANEL

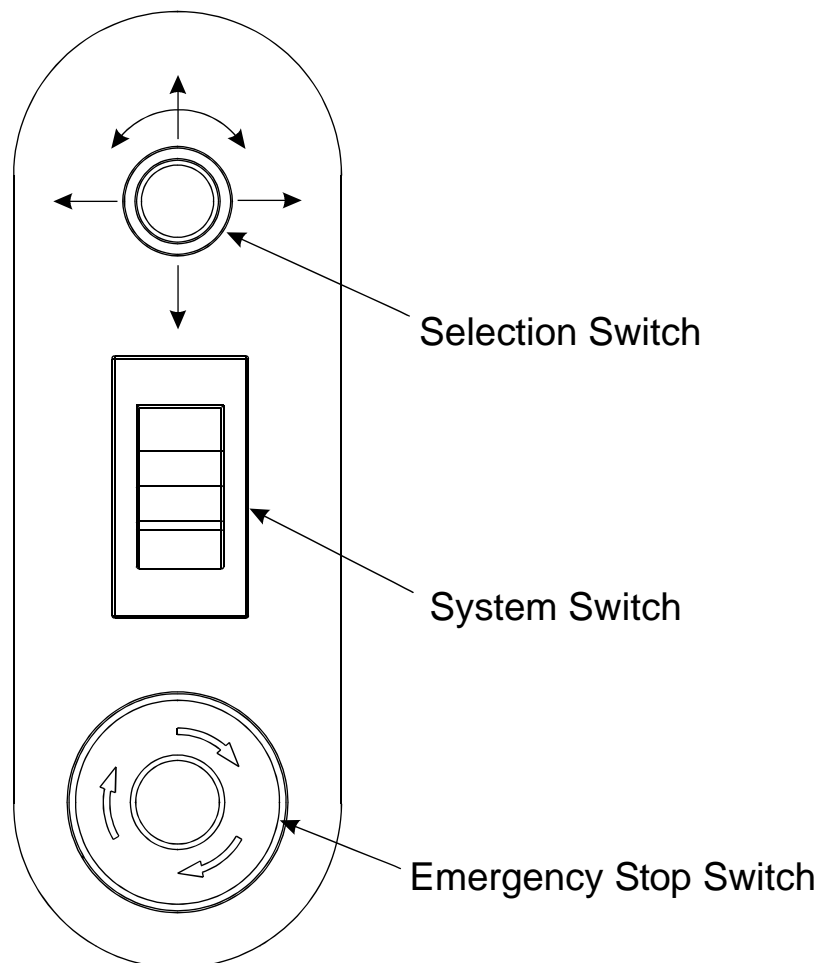

Features on the Control Panel

Selection Switch

Allows the operator to scroll through stored addresses and programs, and to set a crease position.

System switch

When activated the system switch will operate the motors in order to begin the creasing sequence.

Setting the machine

1. Place the stock to be creased onto the loading table against the fixed side lay.
2. Position the adjustable side lay so that the gap between the paper stack and the side lay is approximately 0.5mm (1/64 inch)
3. Turn the Emergency Stop button clockwise to switch the power on. The display unit is now illuminated, a typical start up display menu is shown below.

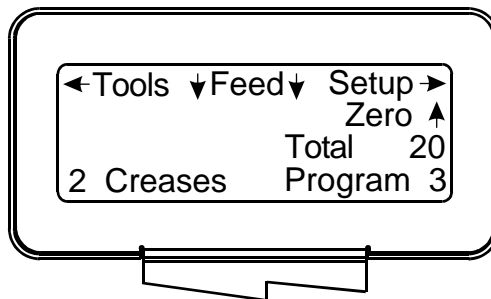

NOTE:-

The arrows on the display denote the direction in which the selection switch must be moved in order to access the various sub-menus.

4. Following the arrows on the display unit; move the selection switch to the right to select **Setup** (i.e. Setting the crease positions), a typical display is shown below.

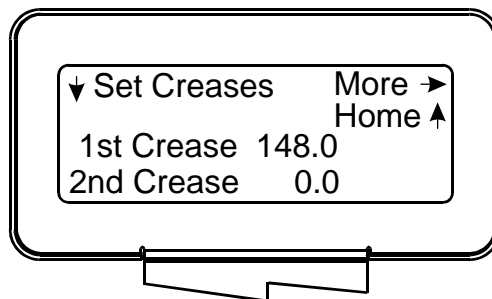

5. Following the arrows on the display unit; move the selection switch down to set the creases. The 1st Crease is now selected.

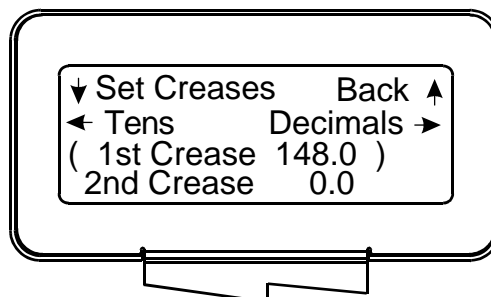

6. Move the selection switch to the left to select the **Tens**, or to the right to select **Decimals**. The **Tens** or **Decimals** (whichever has been selected) can then be adjusted by rotating the Selection Switch, (clockwise to increase or anti-clockwise to decrease).
7. To set the 2nd Crease position move the selection switch down; the 2nd Crease is selected and can be set as described in step 6. Above

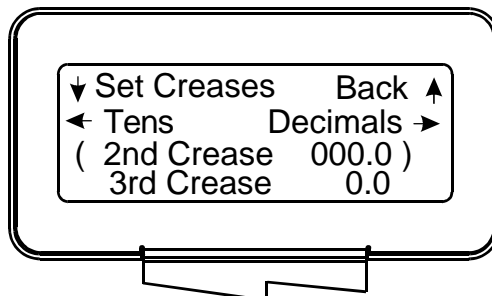

8. Further creases can be set in this way, up to a maximum of nine creases.
9. When the required creases have been set, move the selection switch up step by step until the display contains the word **Feed**, see below.

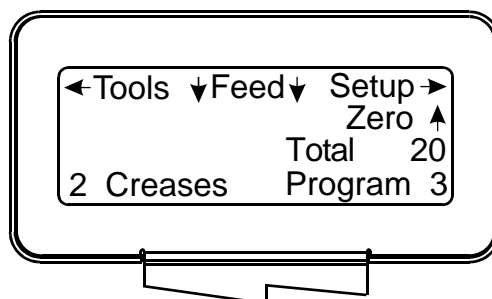

10. Move the selection switch to the right to select **Setup**.
11. Move the selection switch to the right again to select **More**.
12. Move the selection switch up or down to select **High Speed** or **Low Speed**.
13. Move the selection switch to the right to select **Ok**.
14. Move the selection switch up step by step until the display contains the word **Feed**.
15. Press the System Switch down, the display will momentarily read **Please Wait Initiating** and then return to show **High Speed** or **Low Speed**.
16. Move the selection switch down to select **Feed**, and feed the sheets individually into the rollers.
17. When the sheets have been fed into the machine and creased; move the selection switch up, to select **Stop Feeding**, and then press the System Switch up to stop the machine.

Setting the Adjustable Side Lay

Place the paper stack on to the loading table and slide up to the fixed side lay. Position the adjustable side lay up towards the paper stack, allow a gap of approx. 0.5mm (1/64 inch) between the paper and the side lay.

Setting the Roller Tilt Mechanism

The roller tilt mechanism has been designed to compensate for when the creasing position on the sheet is not square. This could be due to an inaccuracy in the media or if the roller tilt mechanism has been incorrectly set. The mechanism will be set to zero (square) when the machine is supplied.

To set the mechanism, unlock the roller tilt knob located below the roller tilting handle by turning anti-clockwise. Move the roller tilt handle left or right in order to compensate for any inaccuracy. When the position is set, ensure to lock the roller tilt knob before operating the machine. Repeat the above procedure until the creasing position is square.

Setting the positions of drive wheels and hubs

It is important that the drive wheels and drive hubs on the roller shafts are arranged evenly across the width of the media being creased. This is done to ensure that the media is accurately driven and supported through the rollers.

The drive wheels and hubs are fixed to the rollers by means of a grub screw. To locate this grub screw the rollers can be rotated by operating the motor manually.

DO NOT ROTATE THE DRIVE ROLLERS BY HAND.

To operate the motors manually, switch the machine 'on' at the Emergency Stop switch. Following the arrows on the display unit, move the selection switch to the left to select **Tools**, the display will now show the Tools sub-menu. Press the system switch down and then move the selection switch to the left or to the right, to rotate the rollers in short pulses. Lift the exit guard to see if the grub screws in the drive wheels and hubs can be seen. If the grub screws cannot be seen, lower the exit guard and rotate the rollers by moving the selection switch to the left or to the right. Loosen the drive wheels and hubs with a 2mm allen key. Arrange the drive wheels and hubs as shown in FIG 10.1. In order to avoid marking on some types of media ensure a gap between the drive wheels and hubs. This procedure should be repeated when installing perforating blades and anvils onto the drive wheels and hubs.

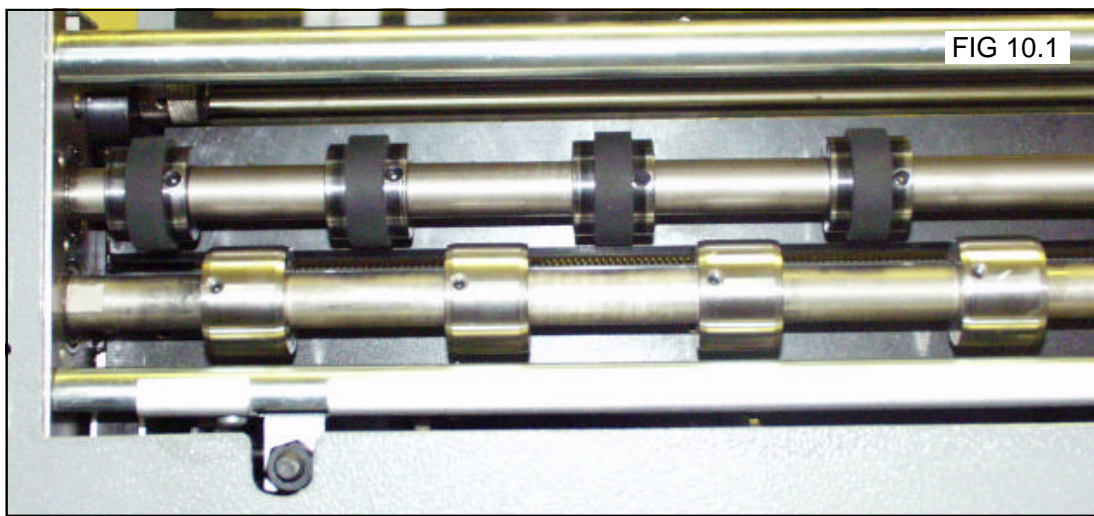

Programming the machine

1. Switch the power 'on' by turning the Emergency stop button clockwise to release the safety latch. The display is now switched on.

Setting the crease positions

2. Move the selection switch up, one click at a time, until the start up menu is displayed as shown below.

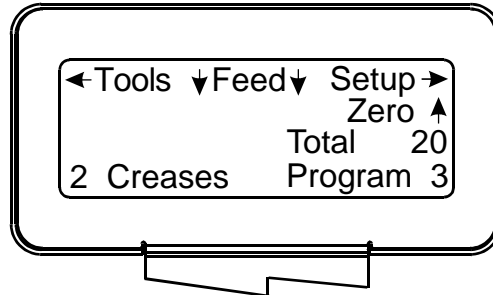

- (i) Move the selection switch to the right to select **Setup**.
- (ii) Move the selection switch down to select **Set Creases**.
- (iii) Move the selection switch to the left to select **Tens**, or to the right to select **Decimals**.
- (iv) The **Tens** or **Decimals** (whichever has been selected) can then be adjusted by Rotating the Selection Switch, (clockwise to increase or anti-clockwise to decrease).
- (v) Adjust all other digits for the 1st Crease position as described in steps (iii) and (iv), (I.e. move the selection switch to the left to select the Tens or to the right to select Decimals and then rotate the Selection Switch to adjust its value.
- (vi) Move the selection switch down to select the 2nd Crease. The second crease will automatically start at 0000.0. Crease positions can be set in increments of 0.1mm.
- (vii) Set the 2nd Crease position as described in steps (iii) to (v) above.
Further creases can be set in this way, up to a maximum of nine creases.

Storing the crease positions

3. Once the crease positions are correctly entered, they can be stored as follows.
 - (i) Move the selection switch up, one click at a time, until the display contains the word **More**.
 - (ii) Move the selection switch to the right, one click at a time, until the display contains the word **Programs**.
 - (iii) Move the selection switch down to select **Save All Settings**.
 - (iv) Move the selection switch to the right to select **Ok**.
 - (v) Move the selection switch to the right or to the left to select **Program 1** to **Program 9**.
 - (vi) Move the selection switch up to save the program in the selected program number.
 - (vii) Move the selection switch up to select **Ok**.

Setting the Speed (High Speed or Low Speed)

4. (i) Move the selection switch to the right to select **Setup**.
- (ii) Move the selection switch to the right again to select **More**.
- (iii) Move the selection switch up or down to select **High Speed** or **Low Speed**.
- (iv) Move the selection switch to the right to select **Ok**.
- (v) Move the selection switch up, step by step, until the display contains the word **Feed**.

Running the machine

5. To run the job with the selected settings.
 - (i) Press the System Switch down, the display will momentarily read **Please Wait Initiating** and then return to show **High Speed** or **Low Speed**.
 - (ii) Move the selection switch down to select **Feed**, and feed the sheets individually into the rollers.
 - (iii) When the sheets have been fed into the machine and creased; move the selection switch up, to select **Stop Feeding**, and then press the System Switch up to stop the machine.

Reading stored programs

Any of the nine stored programs can be accessed and read as follows:-

- (i) From the start up menu, move the selection switch to the right to select **Setup**.
- (ii) Move the selection switch to the right, one click at a time, until the display contains the word **Program**.
- (iii) Move the selection switch down to select, **Select Retrieve Settings**.
- (iv) Move the selection switch to the right to select, **Ok**.
- (v) Move the selection switch to the right or to the left to select, **Program 1** to **Program 9**.
- (vi) Move the selection switch up to select, **Load**.
- (vii) Move the selection switch up again to select, **Ok**.

The details of the selected program can now be viewed or edited.

Paper jamming

In the event of a paper jam occurring whilst the machine is operating the display will read **Paper Jam**. In order to remove the paper causing the jam, move the selection switch to the left or to the right to drive the paper forwards or backwards in short pulses.

The stacker unit on the DigiCreaser is used to catch the sheets once they have been creased or perforated.

Setting the Stacker assembly

1. Assemble the stacker unit to the machine as shown in fig 13.1 below.

Important

Ensure that the stacker unit has been assembled to the machine properly. However, if it has not, the connection on the magnetic switch will be broken and the machine will not operate (see Trouble shooting pages for details).

There are two side guides on the stacker unit; a left handed guide and a right handed guide.

The guides will control the way in which the paper is collated by setting their positions on the stacker bed.

2. Place a single sheet (from the stack to be creased / perforated) on to the stacker bed against the 'left hand' guide.
3. Position the 'right hand' side guide on to the stacker bed leaving a minimum clearance of approximately 1mm each side of the sheet.

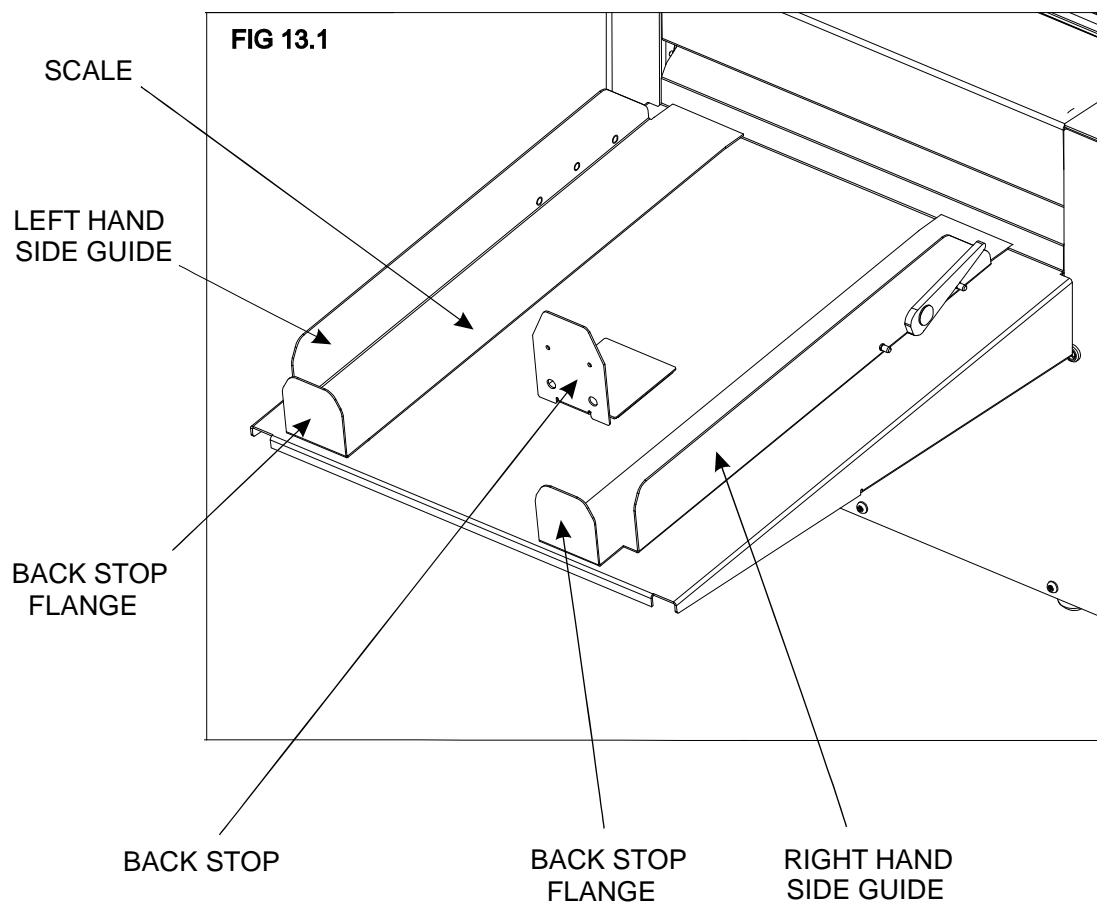

4. Whilst the sheet is between the two guides on the stacker bed, set the distance between the top of the sheet and the backstop flanges to approximately 5mm.
5. For shorter sheets, the back stop can be used (as shown in FIG 13.1 to adjust the position of the paper stack.

Once the machine is set-up, the DigiCreaser can be used to perforate or crease.

Note

Perforating and creasing can be carried out simultaneously. However, if any adjustment is made to the roller tilt mechanism in order to compensate for the perforation line being 'out of square', this may effect the accuracy of the crease. If this occurs creasing and perforating must be carried out as separate operations.

The components and tools required to install the perforator are contained in the despatch kit supplied with the machine, they are listed below.

- 1 off Set of standard perforation '56 tooth' blades.
- 1 off Set of standard hardened anvils.
- 1 off Perforator stripper.
- 1 off Scoring wheel
- 1 off 3mm bondhus wrench / allen key
- 1 off 2mm bondhus wrench / allen key

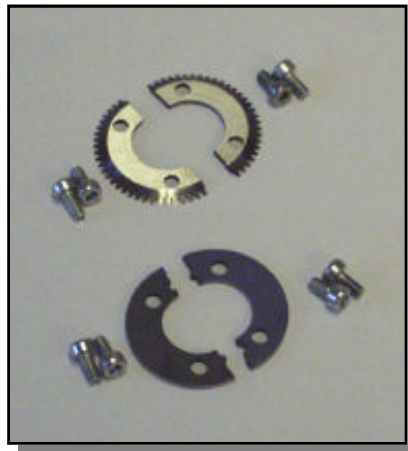

The perforator blades are split into two matching halves and are fitted to the drive wheels as shown in the photograph using the four screws supplied.

A hardened anvil is fitted to the drive hub as shown in the photograph also using the four screws supplied. Again the anvils are made from matching halves.

Important: The perforator blades are very sharp and care must be taken whilst handling. Do not mix the matching pairs of blades or anvils.

Perforating 'Spares' kits

For perforating and other types of paper, various spares kits are available which can be assembled to the machine in the same fashion. They are listed below along with a range of scoring wheels,

Perforating blades	56 teeth	Part Number 1-99-41	–	Standard stock / fine perforations.
	28 teeth	Part Number 1-99-12	–	Medium stock / medium perforations.
	20 teeth	Part Number 1-99-10	–	Heavy stock / coarse perforations.
Anvils	Standard	Part Number 1-99-35	–	For all blade types

All of the blades and anvils are supplied with fixings.

***Perforator stripper** Standard Part Number **78-013**

*It is recommended that for multiple perforations, a separate perforator stripper is used for every perforating blade set fitted in the creasing unit.

Setting the machine

1. Turn the mains supply to the machine 'off'.
2. Remove the stacker unit and open the exit guard.
3. Locate and remove the blades / anvils from the despatch kit supplied with the machine.
4. Using the 2mm allen key (supplied), loosen the drive wheel that is to accommodate the blades.
5. Slide the drive wheel away from any obstructing drive wheels or hubs in order to mount the blades.

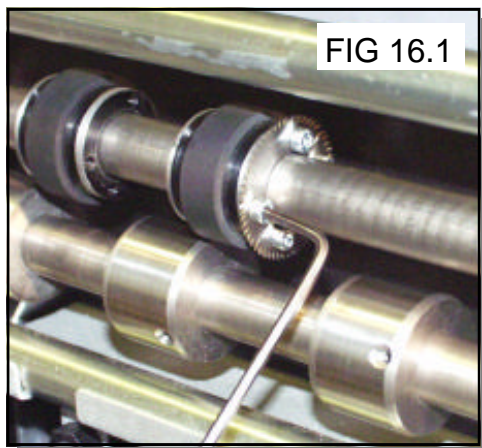

6. Using the 2.5mm allen key (supplied), take one of the matching pairs and mount on to the drive wheel. Do not secure the blade.
7. Mount the other matching pair to the drive wheel as shown (fig 16.1). Secure the blades to the wheel ensuring not to over tighten grub screw.
8. Mark on a single sheet the desired perforating position. Feed the sheet through the machine manually until the mark can be seen. Use this mark to assist in fixing the position of the perforating drive wheel to the roller drive shaft.

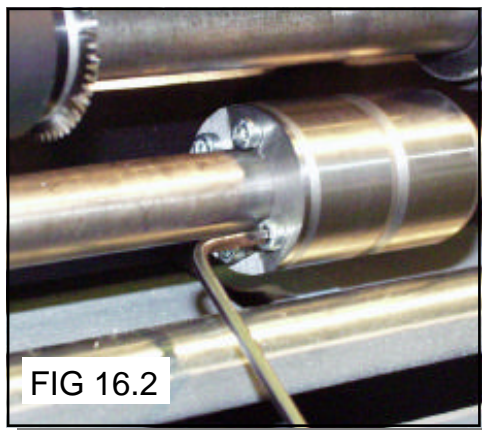

9. Using the 2mm allen key, loosen the drive hub nearest the perforating drive. Slide the drive hub away from any obstructing drive wheels or hubs in order to mount the anvils.
10. Using the 2,5mm allen key, take one of the matching pairs of anvils and mount to the drive hub. Do not secure the anvil.

11. Mount the other anvil ensuring that they have matched on the drive hub. Secure the anvil to the hub ensuring not to over tighten grub screw as shown in fig 16.2.
12. Slide the drive hub towards the perforating drive wheel until there is a clearance of 0.5mm.
13. To prevent damage to the blades or the anvils, do not force the drive wheel against the hub.
14. Fix the perforator stripper adjacent to the drive wheel and blade as shown.
15. Operate the machine and test the perforations for form.

It is important that the drive hubs are arranged evenly across the width of the paper in order to reduce the risk of jamming.

For multiple perforations repeat the above procedure.

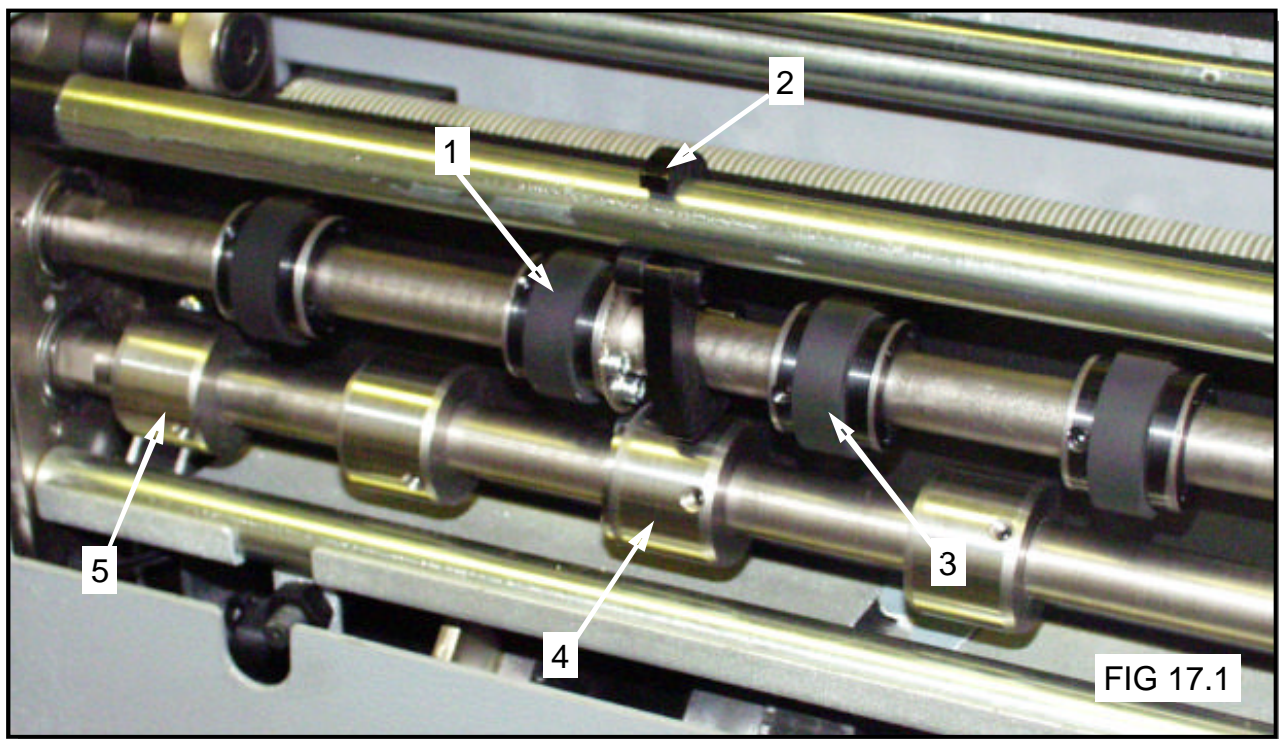

Fig 17.1 demonstrates a typical set-up for perforating sheets.

- | | |
|---|---------------------------------|
| 1 Perforating drive wheel with mounted blades | 4 Drive hub with mounted anvils |
| 2 Perforator stripper | 5 Standard drive hub |
| 3 Standard drive wheel | |

Always remove blades and anvils once the perforating operation has been completed to avoid marking on digital or delicate media.

Adjusting the blade pressure (no paper required)

- (i) Switch the power 'on' by turning the Emergency stop button clockwise to release the safety latch. The display is now switched on and will show the start up menu as shown below.

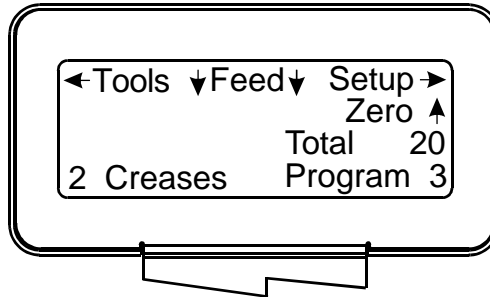

- (ii) Move the selection switch to the left to select **Tools**.
 - (iii) Move the selection switch down to select **Set Blade Pressure**.
 - (iv) Press the system switch down.
 - (v) Move the selection switch to the right, the machine will activate and the blade will move to top dead center. The display will now read **Blade is moving to TOP DEAD CENTER** and then change to read **Blade Pressure May Now Be Adjusted See Operators Manual**.
2. Raise the exit guard
 3. Using a 6mm allen key, unlock the shoulder bolts (labelled with scale transfer) positioned at each end of the creasing blade.
 4. Turn the adjustment cam to adjust the blade pressure. Increasing the gradient on the scale will increase the blade pressure.
 5. Ensure that the shoulder bolts are locked after setting.

The diagram below demonstrates the adjustment of the blade pressure

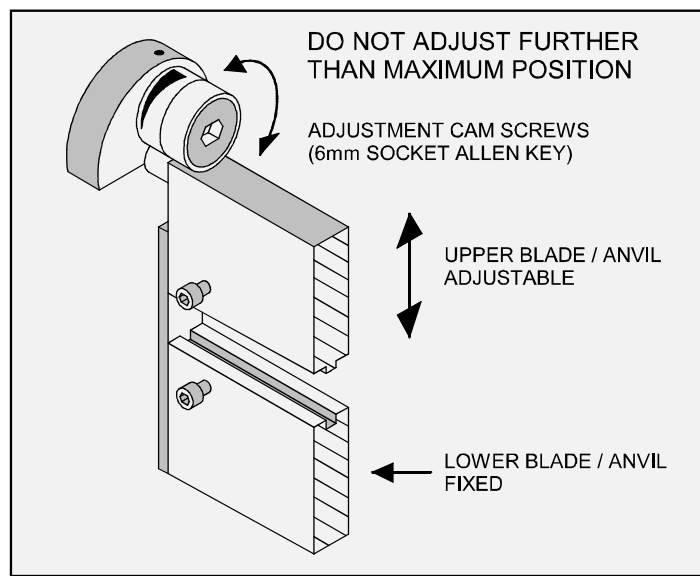

Adjusting the blade alignment

It is extremely important that the blade and anvil assembly within the creasing unit is correctly aligned. Misalignment of the blade or anvil can lead to damaged profiles and subsequently poor quality creasing so it must, therefore, be corrected immediately. If the blade set is misaligned, the media being driven will be subject to scoring or even tearing at any point along the crease line. **Please note that to avoid damage to the blade set, adjustment should only be made in small increments.** The below sketch demonstrates how the blade alignment can be carried out.

Adjustment can be made at either of the blade or anvil. The two clearance holes positioned above the roller tilt mechanism are the front alignment (one for blade, one for anvil). The two holes are repeated on the back of the machine for the back alignment.

1. Remove the stacker unit from the Digicreaser
2. Unlock and centralise the roller tilt mechanism in order to locate the heads of the front alignment screws.
3. Using a 3mm allen key, loosen the cap head type locking screws located on the front face at both ends of the blade /anvil as shown below.
4. Using a 4mm allen key, locate the two front or back alignment screws in the side frame in order to adjust the blade / anvil.
5. The upper screw of the two, will adjust the upper blade / anvil whereas the lower screw will adjust the lower blade / anvil both in very small increments.
6. In order to obtain the required position, adjust either the blade or the anvil by a small amount and then operate the machine to test the form of the crease. Repeat the exercise until centralisation is located.
7. Using a 3mm allen key, lock the cap head type screws (as per step 3) on both the upper and lower blade / anvil.

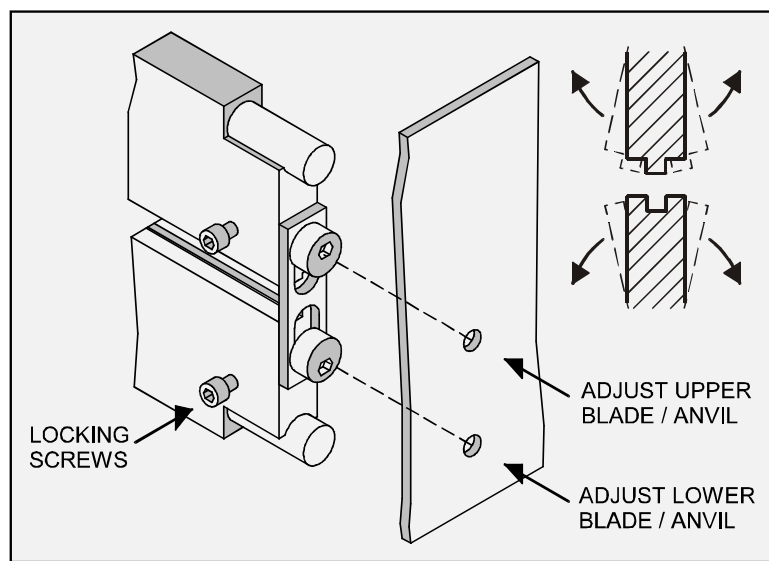

1. Before removing the blade assembly, ensure that the lower blade / anvil is NOT at 'top dead centre', Switch the machine off.
2. Remove the stacker unit and lift the exit guard.

Blade Extractor Tools

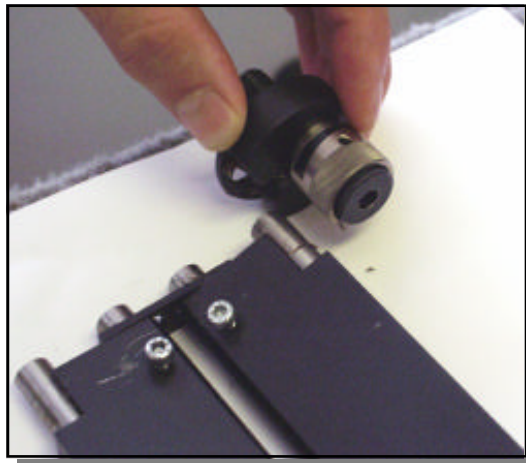
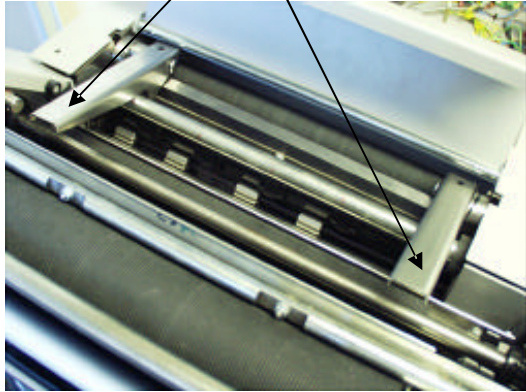

3. Using a 6mm allen key, loosen the socket head screws located inside the blade adjustment cams. Remove the screws and the blade adjustment cams.
4. Insert the blade extractor tools (70-055-01 & 70-055-02) into the holes in the adjustment links, as shown. Push downwards on the handles of the blade extractor tools to release the blade assembly from the power links.
5. Slide the blade assembly out of the creasing unit and lay it on a flat surface.
6. Slide the adjustment links away from the dowels located in the ends of the blades / anvils as shown in the photograph (left)
7. Place the new blade set into position. Check that the eccentric shoulder bolts on the link plates have been positioned as shown in fig 20.1.
8. (Upper blade / anvil only)
Slide the adjustment links onto the dowels.

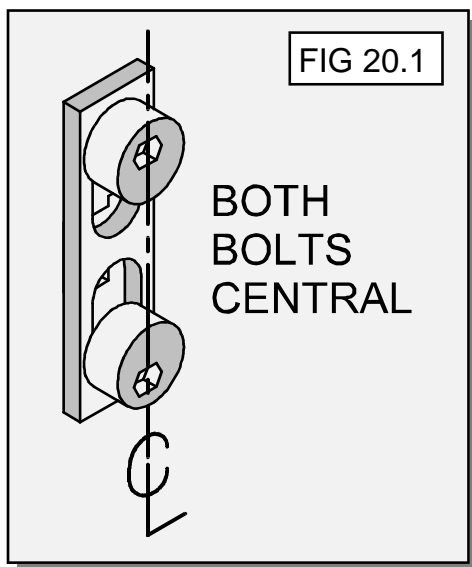

9. Slide the new blade set into the slots of the creasing unit as shown in fig. 21.1.

Locate the blade extractor tools into the holes in the adjustment links as shown. Pull the handles of the blade extractor tools upwards to engage the blade assembly back into the power links.

10. Set the cam graphics for both ends of the blade / anvil to their lowest point on the scale (ie. When the mark on the scale reaches the mark on cam holder) Fasten the socket head screws on the adjustment cams until they are tight.

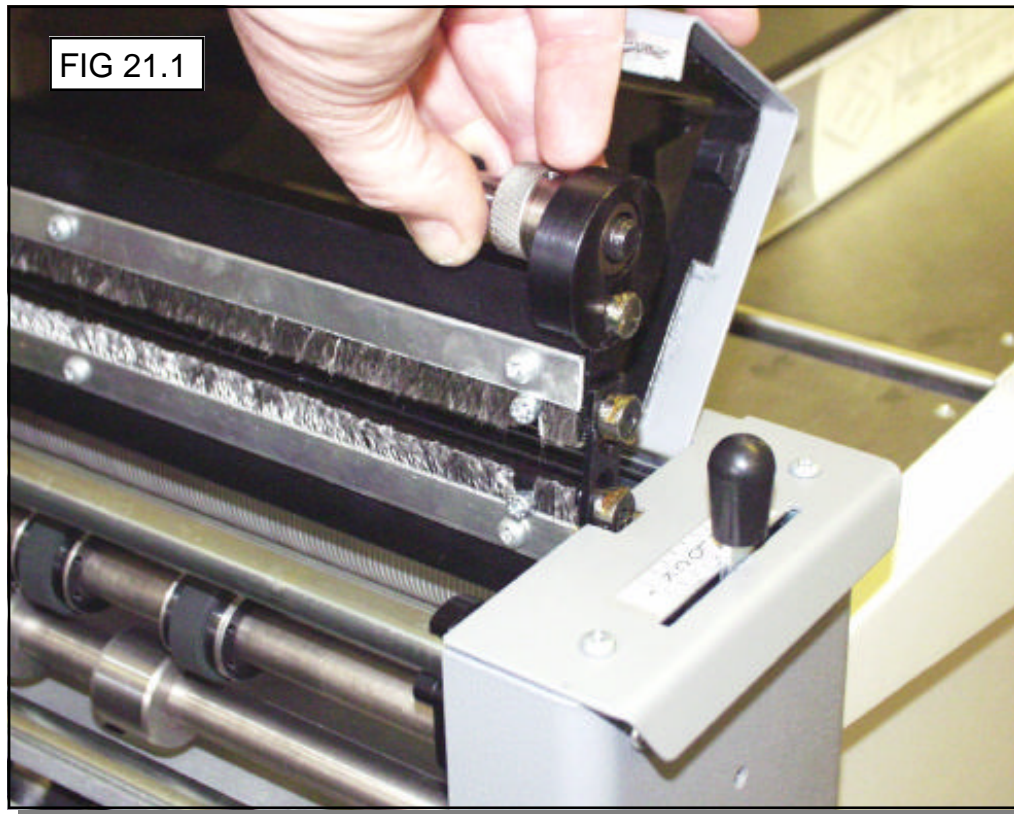

11. Push the exit guard down and replace the stacker assembly before operating the machine.
12. Switch the machine on and test the crease for form.

If the pressure and the alignment of the crease is not to a satisfactory level, see pages 19 –20 to adjust the creasing line.

'Spares' kits

In the event of any damaged or lost components within the blade assembly, spares kits are available on request. However, components within the blade set can not be ordered separately ie single blade or anvil.

Standard Blade set

Part number 76-213-01

Consisting of a standard blade and anvil, blade brushes, blade links and alignment bolts.

Paper crease out of square

- Check that the sheets are all square and exactly the same size before loading the stack on to the table.
- Check that the roller tilt mechanism is correctly set and locked in position.
- Check that the adjustable side lay has been correctly positioned ie. No further than 0.5mm from the paper stack.

Paper jamming

- Check that the first crease position is not too close to the leading edge of the paper. A minimum distance of 32mm is recommended.

Machine will not start

- Check the power supply to the machine.
- Check that the emergency stop button has been released.
- Check that the exit guard is down.
- Check that the stacker unit is located correctly and has not been disconnected from the magnetic switch.
- Check that the lower blade / anvil is connecting to the home switch (mounted below the lower blade / anvil).

Paper not feeding

- Ensure that the adjustable side lay is not pressed against the sheet of paper.
- On digital media, the feeding performance may be improved if the leading edge of the stack is trimmed before loading onto the Digicreaser.



Machine not counting

- Open the exit and remove the blade set (see pages 20-21) to access the dual sensor post located in between the drive rollers. Using a soft brush, clean the visible sensor on the end of the post. Use the brush to clean the sensors between the post and the bottom paper guide which are not visible. Photograph (left) shows the dual sensor post containing the sensors.

Control panel reads

- **Overlap - Probable Cause - Double Sheet**

If the machine is 'cutting out' and the control panel reads **Overlap - Probable Cause - Double Sheet** check that the machine is not feeding multiple sheets.

- **Blade Not Home**

If at any time during the creasing process the control panel reads **Blade Not Home** it is indicating that the lower blade / anvil has not made contact with the HOME switch ie. blade still in top position. Switch the machine off and remove the blade set and ensure that the area is free from obstructions. Return the blade set to the creasing unit and switch the machine on. Operate the machine in the normal sequence, if the display continues to read **Blade Not Home** it is advised to contact a Service Engineer immediately.

- **The Paper Path is not clear**

If before operating the machine the display reads **The Paper Path is not clear** this indicates that there is an obstruction between the upper sensor assembly and the paper guide sensor (as shown in the photograph on page 22). If there is no obvious obstruction in the paper path, switch the machine off and repeat the same procedure as explained above.

Recommended weekly Operator maintenance

- Clean all sensors
- Clean in feed rollers and output drive hubs using the Morgana cleaning kit (Morgana cleaning kit part number – 90-018)
- Remove and clean the blade assembly
- With the blade assembly removed, clean the slots and surrounding area within the creasing unit.

Technician Maintenance

It is recommended that your Morgana DigiCreaser is fully serviced at least once every six months by a factory trained Service Engineer.

ITEM	PART NUMBER	QTY	DESCRIPTION
1	70-087	1	OPERATORS MANUAL - DIGICREASER
2	72-026	1	DIGICREASER QUICK START CHART
3	90-018	1	ROLLER CLEANING KIT
4	613-316	1	POWER CORD - CEE22 TO 3 PIN (UK)
5	403-01-030-006	12	SCREW - SOCKET CAP HEAD - M3 x 6 LG
6	409-01-040-004	1	SCREW - SKT. SET FLAT PT. - M4 x 4 LG
7	620-007	1	HEXAGON BALL DRIVER 2mm
8	620-020	1	HEXAGON BALL DRIVER 2.5mm
9	620-004	1	ALLEN KEY 4mm
10	620-026	1	BONDUS L WRENCH 4mm
11	620-028	1	BONDUS L WRENCH 3mm
12	620-033	1	BONDUS L WRENCH 6mm
13	624-018	1	DISPATCH BOX
14	70-055-01	1	BLADE EXTRACTION TOOL - OP SIDE
15	70-055-02	1	BLADE EXTRACTION TOOL - LAY SIDE
16	08-041-02	1	SLITTING ANVIL - UNDERSIZE.
17	08-066	1	SLITTER PERF BLADE 28T
18	624-017	3	SLITTER/SCORER PK - STYLE 0212/40X40X20

WARNING.....

THE BLADES FOR ANVIL AND PERFORATING SETS ARE SUPPLIED AS MATCHING PAIRS AND SHOULD NOT BE MIXED OR LEFT UNPROTECTED OR SERIOUS DAMAGE MAY RESULT.

ITEM	PART NUMBER	DESCRIPTION
1	1-99-10	PERFORATING BLADE SET 20T (Card)
2	1-99-12	PERFORATING BLADE SET 28T (Single sheets)
3	1-99-41	PERFORATING BLADE SET 56T (Fine perforations)
4	1-99-35	ANVIL SET USED WITH ABOVE BLADE SETS
5	7-05-14	FLOOR STANDING BASE

ACCESSORIES....

....May be obtained from your dealer and fitted to your machine using the instructions supplied, or by reading your operators manual.

OPTIONS....

....May also be obtained and fitted by your dealer. You should not attempt to fit options as specialist tools and knowledge are required.

RECOMMENDED SPARES

Morgana

PART NUMBER	DESCRIPTION
613-365	EMERGENCY STOP SWITCH
652-011	SYSTEM SWITCH
144-04-04	JOYSTICK AND LEAD ASSEMBLY
75-347-01	CONTROL PCB ASSEMBLY
125-21-02	DUAL STEPPER DRIVE PCB ASSEMBLY
75-210-05	LCD DISPLAY UNIT (4 x 20) AND LEAD ASSEMBLY
655-014	PSU - SWITCH MODE - 5V (Used on Machines:- Serial Nos. 770001 TO 770180)
655-011	PSU - SWITCH MODE - 5V / 24V (Used on Machines:- Serial Nos. 770181 Onwards)
655-015	PSU - SWITCH MODE - 24V
655-016	PSU - SWITCH MODE - 48V
613-053	FAN 119mm
76-166	PAPER JAM SENSOR ASSEMBLY
76-167	UPPER SENSOR ASSEMBLY
76-168	PAPER GUIDE ASSEMBLY - Bottom Sensor
98-013	ANTI-STATIC BRUSH
609-022	'O' RING Ø32
606-035	KNOB - Roller Tilt
76-109	POWER LINK BEARING
76-213-01	BLADE SET - 320 Wide - Standard
607-042	TIMING BELT 160XL
607-048	TIMING BELT TWIN GRIP - 200 DXL 050
608-019	SHOULDER BOLT
76-082	PERFORATOR - DRIVE HUB ASSEMBLY
76-083	PERFORATOR - DRIVE WHEEL
76-175-01	INPUT ROLLER - Lower
76-177-01	INPUT ROLLER - Upper
76-019-03	OUTPUT SHAFT
78-013	PERFORATOR STRIPPER ASSEMBLY
613-351	MICRO SWITCH - Guard Circuit
613-191	MICRO SWITCH - Home Circuit
75-040	STACKER SWITCH ASSEMBLY
602-085	BEARING-DRAWN CUP NEEDLE ROLLER Ø10XØ14X10
681-015	FUSE - 4.0A - 20mm x 5mm - ANTI-SURGE

PART NUMBER	DESCRIPTION

NOTE.....
The items listed above represent parts which are subject to wear, loss, or accidental damage, and is included for your guidance only.
Replacement of parts fitted to your machine require specialist knowledge and should therefore be entrusted to your dealer.

PRODUCT RECYCLING & DISPOSAL

European Union

Disposal Information for Commercial Users



Application of this symbol on your equipment is confirmation that you must dispose of this equipment in compliance with agreed national Procedures.

In accordance with European legislation end of life electrical and electronic equipment subject to disposal must be managed within agreed procedures.

Prior to disposal please contact your local dealer or representative for end of life take back information.

Disposal Information for Domestic Users



Application of this symbol on your equipment is confirmation that you should not dispose of the equipment in the normal household waste stream.

In accordance with European legislation, end of life electrical and electronic equipment subject to disposal must be segregated from household waste.

Private households within EU Member States may return used electrical and electronic equipment to designated collection facilities free of charge. Please contact your local disposal authority for information.

In some Member States when you purchase new equipment your local retailer may be required to take back your old equipment free of charge. Please ask your retailer for information.

Other Countries

Please contact your local waste authorities and request disposal information.

